

LED Dimmer-actuator 4 channels RGBW

Code: EK-GC1-TP



Datasheet: STEKGC1TP_EN

KNX actuator for dimming and switching of low-voltage, CV (constant voltage) LED sources. Suitable for applications in home and building automation KNX installations

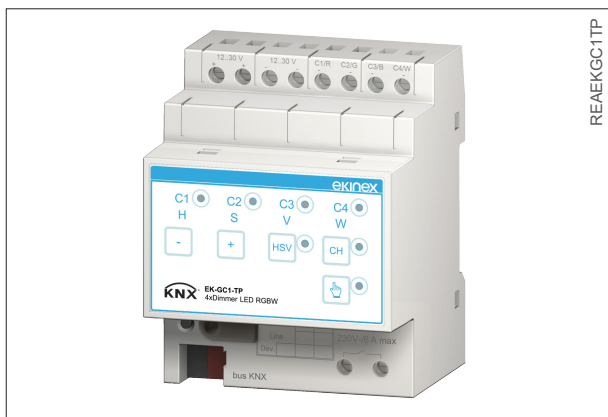

Description

The ekinex® EK-GC1-TP dimming actuator is an S-mode KNX rail mounting modular device for independent switching and dimming of low-voltage (12...30 Vdc) LED lighting devices in CV mode, with PWM modulation. The typical application is with LED strips used for bulk lighting or ambient scenic effects.

Outputs can be managed:

- as 4 independent channel (white or single color);
- as 2 channels, each used for a “dual white” strip (cold and warm white tones);
- combined, as a single RGB (+W) color channel.

The device is equipped with an integrated bus communication module and is designed for rail mounting in distribution boards and cabinets. For its operation, the device receives command telegrams from the bus, sent by a KNX device (such as a pushbutton, a sensor or another switching or control device), that causes the switching or the dimming of the lamp of the connected lighting device. The manual operation of output channels is possible through the membrane pushbuttons on the front of the device. The device is powered by the KNX bus line with SELV voltage 30 Vdc (for the logic section) and requires a 12...30 Vdc auxiliary power supply, with adequate current capacity depending on the connected loads, to provide power for both the output loads and the power drive section.



Note. The loads are low-side switched, i.e. they are required to have a common-anode connection.

Main features

- ON / OFF switching and dimming of the light intensity
- Locking and forced mode for each channel
- Manual operation with membrane pushbuttons
- Color setting in RGB or HSV mode
- Timer programming: delay for on and off switching, staircase lighting function with prewarning signal
- Scene and sequence management
- Operating hours counter configurable by bus
- Independent logic function blocks
- Dry contact output for standby switch-off of the output power supply

Other features

- Plastic material housing, 4 UM (1 UM = 18 mm)
- Mounting on 35 mm rail (according to EN 60715)
- Protection degree IP20 (according to EN 60529) on installed device
- Overvoltage class III (according to EN 60664-1)
- Classification climatic 3K5 and mechanical 3M2 (according to EN 50491-2)
- Pollution degree 2 (according to IEC 60664-1)
- Weight: 160 g
- Dimensions: 72 x 90 x 70 mm (WxHxD)

Technical data

Control section power supply

- Power supply voltage: 30 Vdc from KNX bus
- Current consumption < 13 mA
- Power consumption < 360 mW

Outputs

- Number: 4
- Rated voltage (Un): 12..30 V DC
- Rated current (In): 4 x 4 A
- Switched power (max.): 4 x 120 W

Connectable lighting sources

- Low voltage LED strips or lamps with constant voltage (CV) drive

Environmental conditions

- Operating temperature: - 5 ... + 45°C
- Storage temperature: - 25 ... + 55°C
- Transport temperature: - 25 ... + 70°C
- Relative humidity: 95% (not condensing)

Switching, display and connection elements

The device is equipped with a programming pushbutton and a programming LED, membrane pushbuttons, LED for status indication and terminals for connecting the KNX bus line, the 230 Vac power supply and the outputs.

Control elements

- A pushbutton (6) to switch between the normal and programming operating mode
- A membrane button (4) to switch between the manual operating mode (buttons on the front panel are active) or automatic operating mode (buttons on the front panel not active)
- A membrane button (2) to select current output/parameter
- A membrane button (3) to modify the value of currently selected output/parameter
- A membrane button (5) to select modification mode

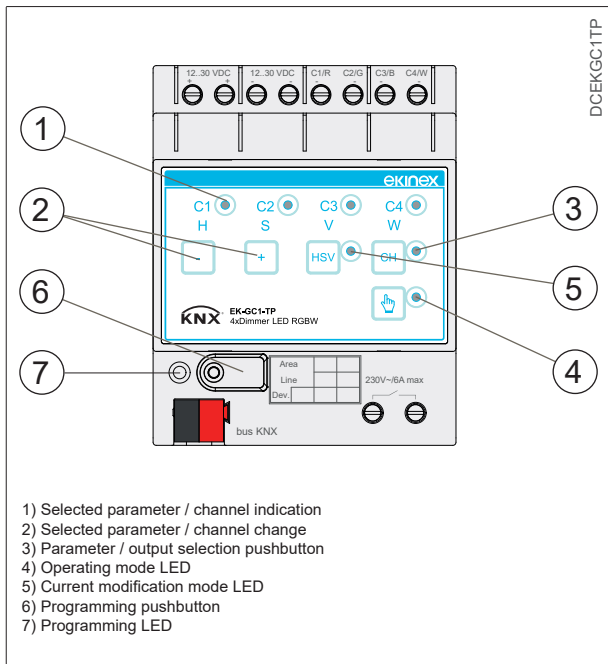

Thanks to the pushbuttons located on the front of the device, the connected loads can be manually controlled when the programming has not yet been carried out.

Pressing the pushbuttons (+, -) for manual control of the output increases or decreases the light intensity or the value of the respective output or parameter.

Display elements

- Red LED (7) to display the active operating mode of the device (on = programming, off = normal operation)
- Green LEDs (1) to display the selected channel or operation mode
- Green LED (5) to display the current modification mode (output channel or color parameter)
- Red LED (4) to display the operating mode (on = manual operation, off = automatic operation)

Mounting

The device has degree of protection IP20, and is therefore suitable for use in dry interior rooms. The housing is made for rail mounting according to EN 60715 in boards or cabinets for electrical distribution. The installation is in horizontal position, the correct position is when the KNX bus terminal and the 230 Vac terminals are located at the bottom and the terminals for the outputs are located at the top.

For the installation of the device on the rail proceed as follows:

- with the aid of a tool bring the locking device in the fully lowered position (a);
- place the upper edge of the rear inner profile on the upper edge of the rail (b);
- rotate the device towards the rail (c);
- push the locking device upward until it stops and locks the device in place (d).

Before removing the device, be sure the outputs and their power supply have been disconnected, and the bus terminal has been extracted from its slot. Use a screwdriver to slide down the locking device and remove the device from the rail.

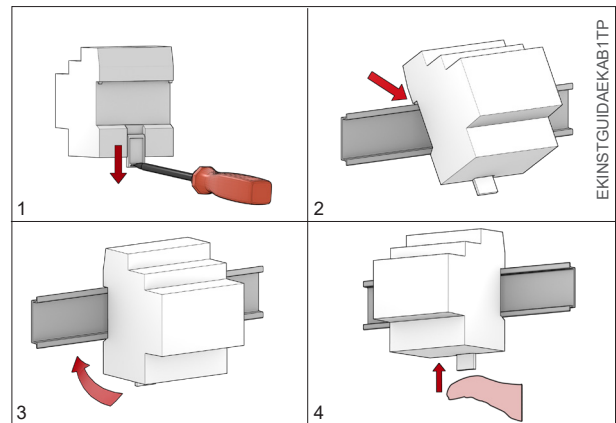

Note. It is recommended that the installation of the device always ensure the full accessibility of the front side *i* to allow the operation of the pushbuttons.

Connection of the KNX bus line

The connection of the KNX bus line is made with the terminal block (black / red) included in delivery and inserted into the slot of the housing.

Characteristics of the KNX terminal block

- spring clamping of conductors
- 4 seats for conductors for each polarity
- terminal suitable for KNX bus cable with single-wire conductors and diameter between 0.6 and 0.8 mm
- recommended wire stripping length: approx. 5 mm
- color coding: red = + (positive) bus conductor, black = - (negative) bus conductor



Warning! In order to supply the KNX bus lines use only KNX bus power supplies (e.g. ekinex EK-AB1-TP or EK-AG1-TP). The use of other power supplies can compromise the communication and damage the devices connected to the bus.

Connection of loads and output power

The connection of the loads and their power supply is made through the screw terminals located on the top side of the device.

Characteristics of the terminals

- cage clamping of conductors
- maximum cross section of conductor 2.5 mm² (single-wire) or 1.5 mm² (multi-wire)
- recommended wire stripping approx. 6 mm
- torque max 0,8 Nm



Warning! The electrical connection of the device substances. can be carried out only by qualified personnel. The incorrect installation may result in electric shock or fire. Before making the electrical connections, make sure the power supply has been turned off.

Connection of the auxiliary contact

The connection of the auxiliary contact is made through the screw terminals located on the bottom side of the device.

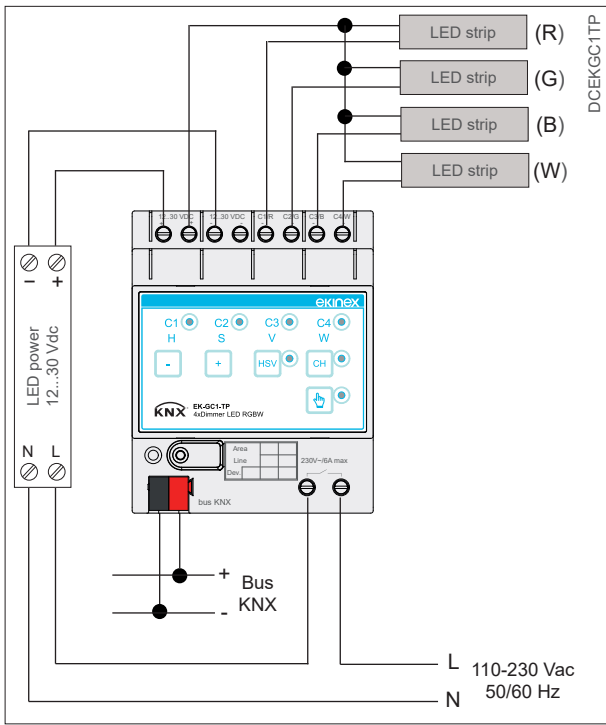

Characteristics of the terminals

- cage clamping of conductors
- maximum cross section of conductor 2.5 mm² (single-wire) or 1.5 mm² (multi-wire)
- recommended wire stripping approx. 6 mm
- torque max 0.5 Nm

Configuration and commissioning

Configuration and commissioning of the device require the use of the ETS[®] (Engineering Tool Software) program V4 or later releases. These activities must be carried out according to the design of the building automation system done by a qualified planner.

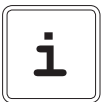

Note. The configuration and commissioning of KNX devices require specialized skills. To acquire these skills, you should attend the workshops at KNX certified training centers.

Configuration

For the configuration of the device parameters the corresponding application program or the whole ekinex[®] product database must be loaded in the ETS program. For detailed information on configuration options, refer to the application manual of the device available on the website www.ekinex.com.

| Code | Application program (## = version) | Communication objects (max. nr.) | Group addresses (max. nr.) |
|-----------|------------------------------------|----------------------------------|----------------------------|
| EK-GC1-TP | APEKGC1TP##.knxprod | 160 | 160 |

Commissioning

For commissioning the device the following activities are required:

- make the electrical connections as described above;
- turn on the bus power supply;
- switch the device operation to the programming mode by pressing the programming pushbutton located on the front side of the housing.

In this mode of operation, the programming LED is turned on;

- download into the device the physical address and the configuration with the ETS[®] program.

At the end of the download the operation of the device automatically returns to normal mode; in this mode the programming LED is turned off. Now the bus device is programmed and ready for use.

Dimensions [mm]

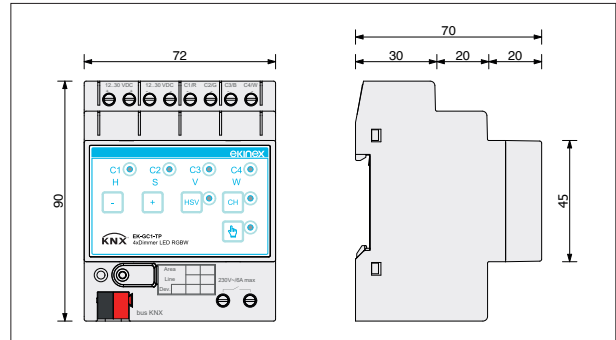

Marks

- KNX
- CE: the device complies with the Low Voltage Directive (2014/35/UE) and the Electromagnetic Compatibility Directive (2014/30/UE). For a detailed list of the valid norms, please refer to the appropriate document declaring their compatibility.

Maintenance

The device is maintenance-free. To clean use a dry cloth. It must be avoided the use of solvents or other aggressive substances.

Smaltimento



At the end of its useful life the product described in this datasheet is classified as waste from electronic equipment and cannot be disposed together with the municipal undifferentiated solid waste.



Warning! Incorrect disposal of this product may cause serious damage to the environment and human health. Please be informed about the correct disposal procedures for waste collecting and processing provided by local authorities.

Document

This datasheet refers to the release A1.0 of the ekinex[®] device EK-GA1-TP, and is available for download at www.ekinex.com as a PDF (Portable Data Format) file.

| File name | Device release | Updating |
|------------------|----------------|-----------|
| STEKGC1TP_IT.pdf | A1.0 | 04 / 2017 |

Warning

- Installation, electrical connection, configuration and commissioning of the device can only be carried out by qualified personnel in compliance with the applicable technical standards and laws of the respective countries
- Opening the housing of the device causes the immediate end of the warranty period
- In case of tampering, the compliance with the essential requirements of the applicable directives, for which the device has been certified, is no longer guaranteed
- ekinex® defective devices must be returned to the manufacturer at the following address: EKINEX S.p.A. Via Novara 37, I-28010 Vaprio d'Agogna (NO) Italy

Other information

- The instruction sheet must be delivered to the endcustomer with the project documentation
- For further information on the product, please contact the ekinex® technical support at the e-mail address: support@ekinex.com or visit the website www.ekinex.com
- KNX® and ETS® are registered trademarks of KNX Association cvba, Brussels

© EKINEX S.p.A. The company reserves the right to make changes to this documentation without notice.